

ATS Series

Multi Function Timer with Free Power, Compact Size W38×H42mm

■ Features

- Wide power supply range
: 100-240VAC 50/60Hz, 24-240VDC universal,
24VAC 50/60Hz, 24VDC universal, 12VDC
- Various output operations (6 operation modes)
- Multi time range (12 types of time range)
- Wide time setting range (0.1 sec to 30 hour)
- Close and DIN rail mounting
with the dedicated socket (PS-M8) width 41mm (for ATS8)
- Easy mounting and installation/maintenance
with the dedicated bracket for DIN 48×48mm



⚠ Please read "Safety Considerations" in the instruction manual before using.



■ Ordering Information

ATS 8 - 4 1

Item	Output	No mark	Time limit DPDT (2c) or Instantaneous SPDT (1c) + Time limit SPDT (1c) selectable by output operation mode
		D	Time limit DPDT (2c)
		E	Instantaneous SPDT (1c) + Time limit SPDT (1c)
	Time range	1	Time range 1 (0.1 to 1)
		3	Time range 3 (0.3 to 3)
	Power supply	1	12VDC
		2	24VAC 50/60Hz, 24VDC
		4	100-240VAC 50/60Hz, 24-240VDC
	Number of plug pins	8	8-pin plug type
		11	11-pin plug type
		ATS	Small Analog Timer

※8-pin socket (PG-08, PS-08(N), PS-M8) and 11-pin socket (PG-11, PS-11(N)) are sold separately.

■ Specifications

Model	ATS8-□1	ATS8-□3	ATS11-□1D	ATS11-□3D	ATS11-□1E	ATS11-□3E
Function	Multi Function Timer					
Control time setting range*1	0.1 sec to 10 hour	0.3 sec to 30 hour	0.1 sec to 10 hour	0.3 sec to 30 hour	0.1 sec to 10 hour	0.3 sec to 30 hour
Power supply	•100-240VAC~ 50/60Hz, 24-240VDC≡ universal		•24VAC~ 50/60Hz, 24VDC≡ universal		•12VDC≡	
Allowable voltage range	90 to 110% of rated voltage					
Power consumption	•Max. 4.2VA (100-240VAC~), Max. 2W (24-240VDC≡) •Max. 4.5VA (24VAC~), Max. 2W (24VDC≡) •Max. 1.5W (12VDC≡)		•Max. 3.5VA (100-240VAC~), Max. 1.5W (24-240VDC≡) •Max. 4VA (24VAC~), Max. 1.5W (24VDC≡) •Max. 1W (12VDC≡)		•Max. 4.2VA (100-240VAC~), Max. 2W (24-240VDC≡) •Max. 4.5VA (24VAC~), Max. 2W (24VDC≡) •Max. 1.5W (12VDC≡)	
Return time	Max. 100ms					
Timing operation	Power ON Start		Signal ON Start			
Min. input signal width	—		START, INHIBIT, RESET: approx. 50ms			
Input	—		START, INHIBIT, RESET: [No-voltage input] - Short-circuit impedance: max. 1kΩ, Residual voltage: max. 0.5VDC, Open-circuit impedance: min. 100kΩ			
Control output	Contact type	Time limit DPDT (2c) or Instantaneous SPDT (1c) + Time limit SPDT (1c) selectable by output operation mode		Time limit DPDT (2c)		Instantaneous limit SPDT (1c) + Time limit SPDT (1c)
	Contact capacity	250VAC~ 3A, 30VDC≡ 3A resistive load		250VAC~ 3A, 24VDC≡ 3A resistive load		
Relay life cycle	Mechanical	Min. 10,000,000 operations				
	Electrical	Min. 100,000 operations (250VAC 3A resistive load)				

*1: Refer to time specifications for control time setting range by model.

Compact Multi Function Analog Timer

Specifications

Model	ATS8-□1	ATS8-□3	ATS11-□1D	ATS11-□3D	ATS11-□1E	ATS11-□3E
Repeat error	Max. ±0.2% ±10ms					
SET error	Max. ±5% ±50ms					
Voltage error	Max. ±0.5%					
Temperature error	Max. ±2%					
Insulation resistance	Over 100MΩ (at 500VDC megger)					
Dielectric strength	2,000VAC 50/60Hz for 1 min					
Noise immunity	ATS□-1□□	±500V the square wave noise (pulse width 1μs) by noise simulator				
	ATS□-2□□					
	ATS□-4□□					
Vibration	Mechanical	0.75mm amplitude at frequency of 10 to 55Hz (for 1min) in each X, Y, Z direction for 1hour				
	Malfunction	0.5mm amplitude at frequency of 10 to 55Hz (for 1min) in each X, Y, Z direction for 10min				
Shock	Mechanical	300m/s ² (approx. 30G) in each X, Y, Z direction 3 times				
	Malfunction	100m/s ² (approx. 10G) in each X, Y, Z direction 3 times				
Environment	Ambient temp.	-10 to 55°C, storage: -25 to 65°C				
	Ambient humi.	35 to 85%RH, storage: 35 to 85%RH				
Approval	CE c  us					
Accessory	Bracket					
Weight ^{※2}	Approx. 95g (approx. 70g)					

※2: The weight includes packaging. The weight in parenthesis is for unit only.

※Environment resistance is rated at no freezing or condensation.

Connections

○ ATS8

●When selecting [A], [F] output operation mode

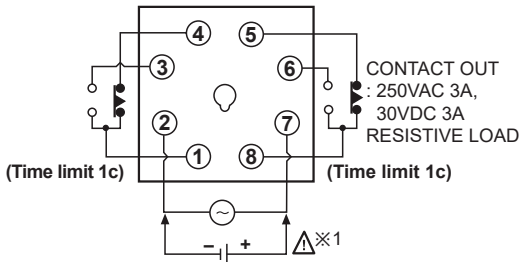

※1: AC/DC voltage: 100-240VAC 50/60Hz, 24-240VDC
24VAC 50/60Hz, 24VDC
DC voltage: 12VDC

○ ATS11-□□D

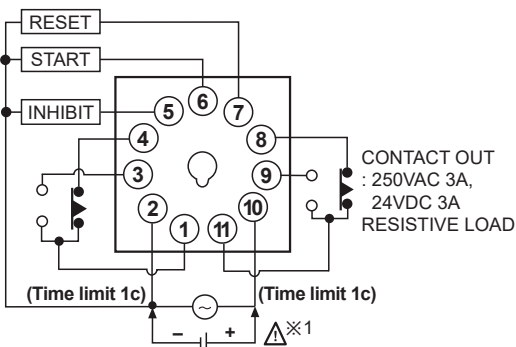

※1: AC/DC voltage: 100-240VAC 50/60Hz, 24-240VDC
24VAC 50/60Hz, 24VDC
DC voltage: 12VDC

●When selecting [A1], [B], [F1], [I] output operation mode

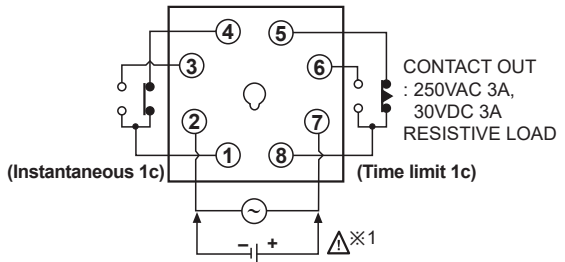

○ ATS11-□□E

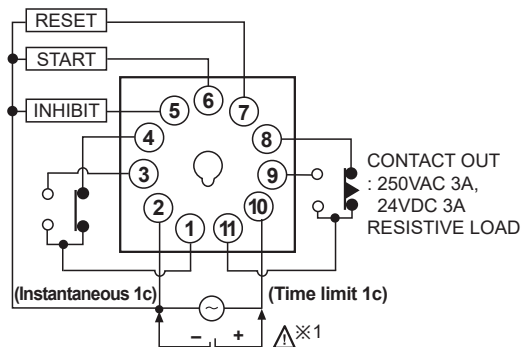

SENSORS

CONTROLLERS

MOTION DEVICES

SOFTWARE

(J) Temperature Controllers

(K) SSRs

(L) Power Controllers

(M) Counters

(N) Timers

(O) Digital Panel Meters

(P) Indicators

(Q) Converters

(R) Digital Display Units

(S) Sensor Controllers

(T) Switching Mode Power Supplies

(U) Recorders

(V) HMIs

(W) Panel PC

(X) Field Network Devices

ATS Series

(unit: mm)

■ Dimensions

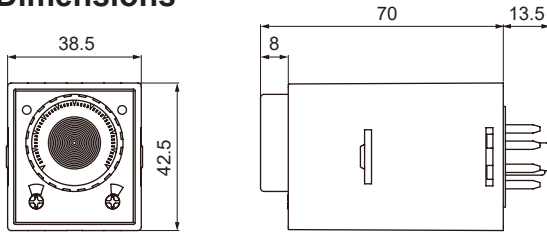

○ Bracket

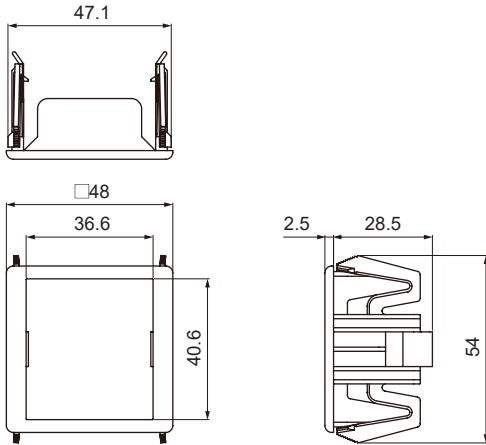

○ Panel cut-out

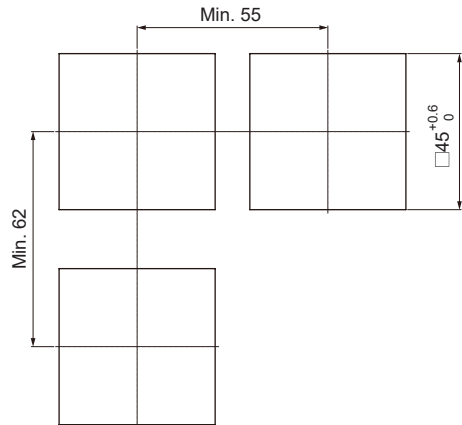

■ Unit Description

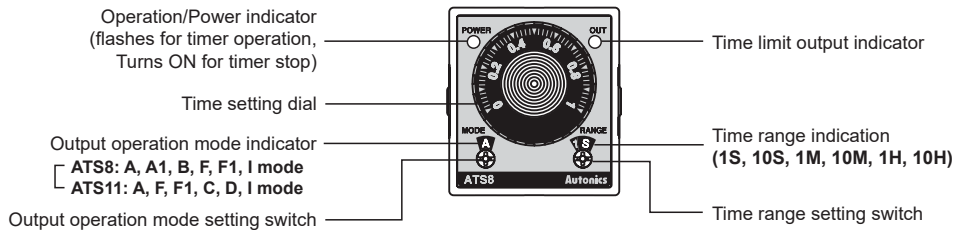

■ Time Specifications

Model	Time range	Time unit	Time setting range
ATS□-□1□	1S	SEC	0.1 to 1 sec
	10S		1 to 10 sec
	1M	MIN	0.1 to 1 min
	10M		1 to 10 min
	1H	HOUR	0.1 to 1 hour
	10H		1 to 10 hour
ATS□-□3□	1S	SEC	0.3 to 3 sec
	10S		3 to 30 sec
	1M	MIN	0.3 to 3 min
	10M		3 to 30 min
	1H	HOUR	0.3 to 3 hour
	10H		3 to 30 hour

■ Output Operation Mode

○ ATS8

Display	Output operation mode
A	Power ON Delay
A1	Power ON Delay 1 (One-Shot output)
B	Power ON Delay 2
F	Flicker (OFF Start)
F1	Flicker 1 (ON Start)
I	Interval

○ ATS11

Display	Output operation mode
A	Signal ON Delay
F	Flicker (OFF Start)
F1	Flicker 1 (ON Start)
C	Signal OFF Delay
D	Signal ON/OFF Delay
I	Interval

Compact Multi Function Analog Timer

■ Output Operation Mode (ATS8)

[t: Set ing time, t>t-a, Rt: Return time, Rt1>Rt]

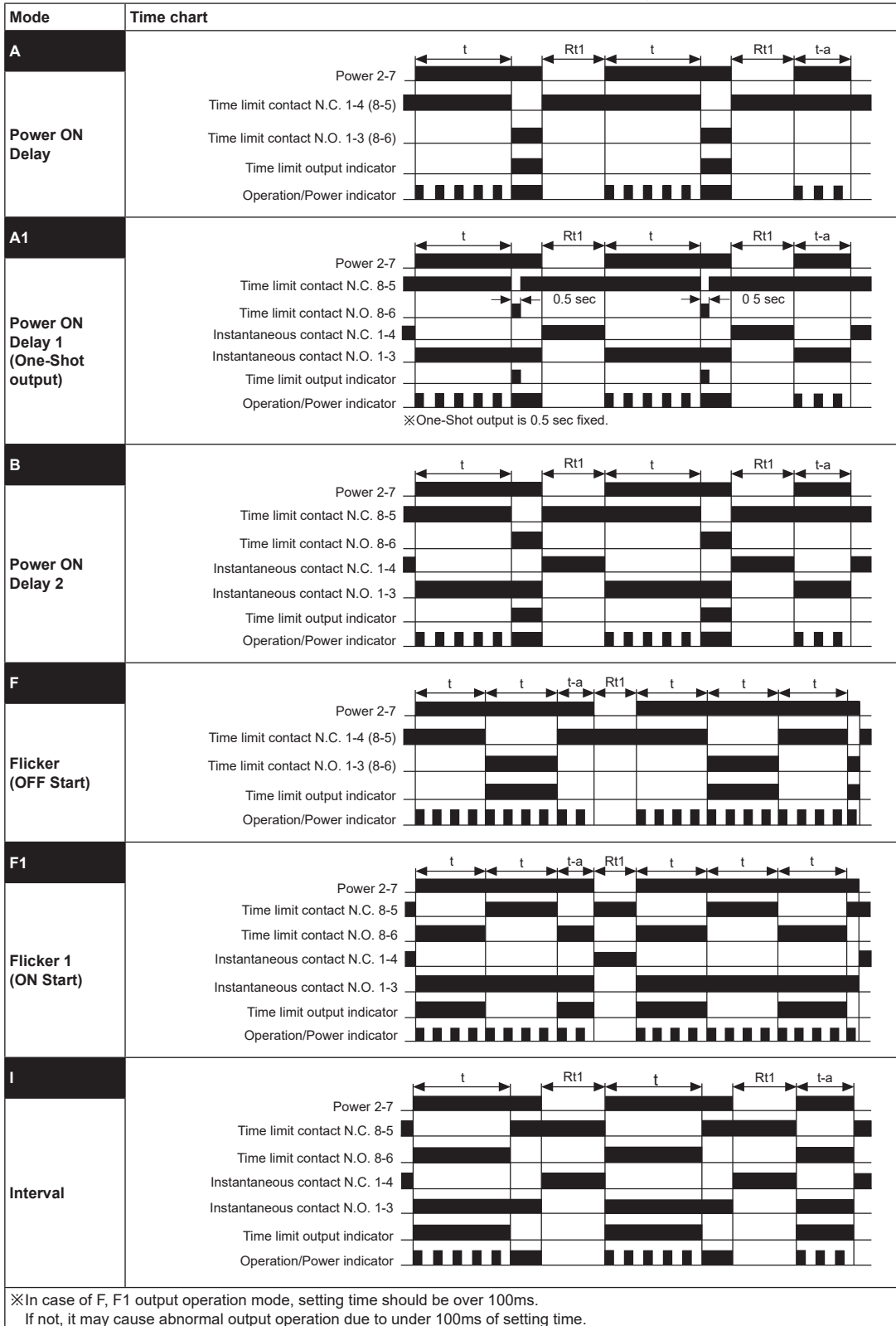

※In case of F, F1 output operation mode, setting time should be over 100ms.
If not, it may cause abnormal output operation due to under 100ms of setting time.

SENSORS
CONTROLLERS
MOTION DEVICES
SOFTWARE

(J) Temperature Controllers
(K) SSRs
(L) Power Controllers
(M) Counters
(N) Timers

(O) Digital Panel Meters
(P) Indicators
(Q) Converters

(R) Digital Display Units
(S) Sensor Controllers
(T) Switching Mode Power Supplies
(U) Recorders

(V) HMIs
(W) Panel PC
(X) Field Network Devices

Output Operation Mode (ATS11)

[t: Setting time, $t=t_1+t_2$, $t>t-a$]

Mode	Time chart
A Signal ON Delay	<p>Power 2-10 START 2-6 INHIBIT 2-5 RESET 2-7 Time limit contact N.C. Time limit contact N.O. Instantaneous contact N.C. Instantaneous contact N.O. Time limit output indicator Operation/Power indicator</p>
F Flicker (OFF Start)	<p>Power 2-10 START 2-6 INHIBIT 2-5 RESET 2-7 Time limit contact N.C. Time limit contact N.O. Instantaneous contact N.C. Instantaneous contact N.O. Time limit output indicator Operation/Power indicator</p>
F1 Flicker 1 (ON Start)	<p>Power 2-10 START 2-6 INHIBIT 2-5 RESET 2-7 Time limit contact N.C. Time limit contact N.O. Instantaneous contact N.C. Instantaneous contact N.O. Time limit output indicator Operation/Power indicator</p>
C Signal OFF Delay	<p>Power 2-10 START 2-6 INHIBIT 2-5 RESET 2-7 Time limit contact N.C. Time limit contact N.O. Instantaneous contact N.C. Instantaneous contact N.O. Time limit output indicator Operation/Power indicator</p>
D Signal ON/OFF Delay	<p>Power 2-10 START 2-6 INHIBIT 2-5 RESET 2-7 Time limit contact N.C. Time limit contact N.O. Instantaneous contact N.C. Instantaneous contact N.O. Time limit output indicator Operation/Power indicator</p>
I Interval	<p>Power 2-10 START 2-6 INHIBIT 2-5 RESET 2-7 Time limit contact N.C. Time limit contact N.O. Instantaneous contact N.C. Instantaneous contact N.O. Time limit output indicator Operation/Power indicator</p>

※ATS11-□□E model only supports Instantaneous contact.

※If power is cut or the RESET terminal is short-circuited, the timer will be RESET.

※If the INHIBIT terminal is short-circuited during a time limit operation, the time will stop.

※In case of F, F1 output operation mode, setting time should be over 100ms.

If not, it may cause abnormal output operation due to under 100ms of setting time.

Compact Multi Function Analog Timer

■ Proper Usage

○ Flicker mode

- Flicker mode which needs 3 subsidiary relays and 2 timers is available with an ATS timer. You can organize flicker function economically.
- START it with a switch A and RESET it with a switch B.

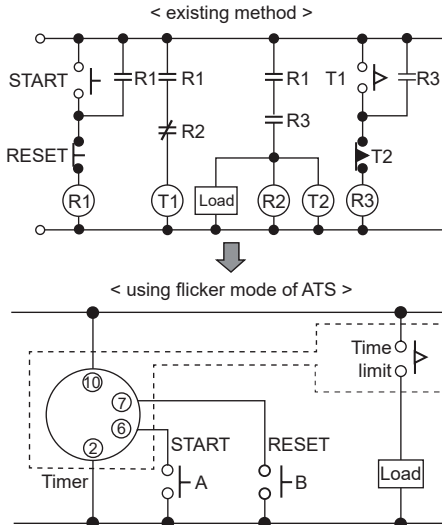

○ Interval mode

When using interval mode, you can simply organize Instantaneous ON, Time limit OFF (self hold circuit).

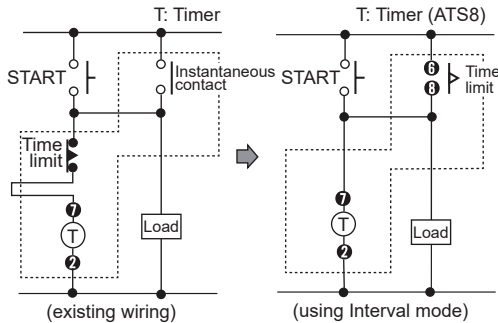

○ Conditions of input signal (ATS11-□□D, ATS11-□□E)

1. Input with contact

Use a switch which is gilded and has good reliability of contact.

Use a switch which has short bound(chattering) time for input contact because bound(chattering) time of contact timer may be error for operation time. Open resistance should be over 100kΩ and short resistance should be below 1kΩ.

※Use contact which has good reliability to open/close for 0.4mA small current.

2. Input with NPN open collector type

Characteristics of transistor should be $V_{ce0} = \text{Min. } 25V$, $I_c = \text{Min. } 10mA$, $I_{cbo} = \text{Max. } 0.2\mu A$, residual voltage = Max. 0.5V.

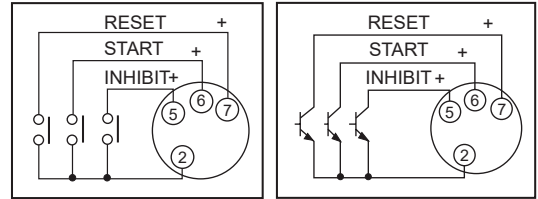

3. Input with NPN universal type

For non-contact circuit (proximity sensor, photoelectric sensor, etc.) which output voltage range is 10-30VDC, voltage output is also available as input signal not as open collector output.

In this case, when signal changes from H to L, a timer starts. Residual voltage should be below 0.5V when transistor (Q) is ON.

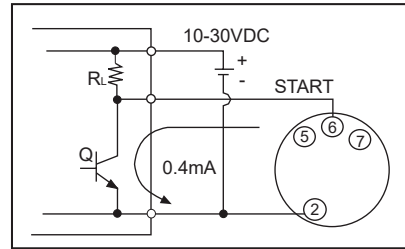

○ Terminal connection

- Refer to the connection diagrams and wire it correctly.
- Power connection

For power connection of ATS Series, when it is AC power, connect it to the designated power terminal regardless of polarity. When it is DC power input after checking polarity of power.

Power voltage	8-pin type	11-pin type
AC type	Terminal ② - ⑦	Terminal ② - ⑩
DC type	Terminal ② - ⊖ Terminal ⑦ - ⊕	Terminal ② - ⊖ Terminal ⑩ - ⊕

- Turn OFF a power switch and be sure not to supply induced voltage, residual voltage between timer power terminals. (when wiring power cable parallel with high voltage line, power line, induced voltage may occur between power terminals.)
- For DC power, ripple should be below 10% and power voltage should be within the allowable range.
- When applying the power to the Timer, please apply the rated power at the moment by switch, relay, etc. Otherwise it might cause malfunction.
- Load for control output should be below the rated load capacity.

SENSORS
CONTROLLERS
MOTION DEVICES
SOFTWARE
(J) Temperature Controllers
(K) SSRs
(L) Power Controllers
(M) Counters
(N) Timers
(O) Digital Panel Meters
(P) Indicators
(Q) Converters
(R) Digital Display Units
(S) Sensor Controllers
(T) Switching Mode Power Supplies
(U) Recorders
(V) HMIs
(W) Panel PC
(X) Field Network Devices

◎ Changing of setting time, time range, operation mode

It might cause malfunction if changing the setting time, time range or operation mode during operating unit. Please Change the setting time, time range or operation mode after cut the power off.

◎ Input connection

- Power circuit of ATS11-□□D/ATS11-□□E timer does not use trans. Use isolation transformer which secondary part is not grounded as (Figure 1) to cut off peripheral current flow for supplied power to external input devices.

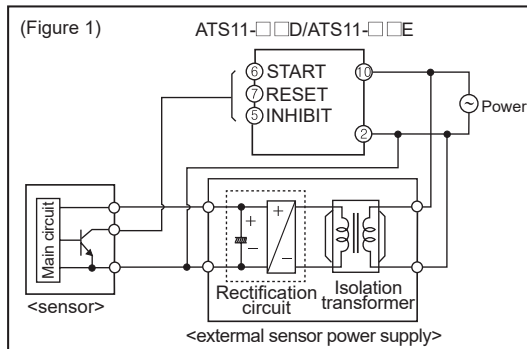

- As (Figure 2), if using terminal ⑩ as common terminal of input signal, it may cause damage to inner circuit of ATS11 timer. Use terminal ② as common terminal referring to (Figure 3).

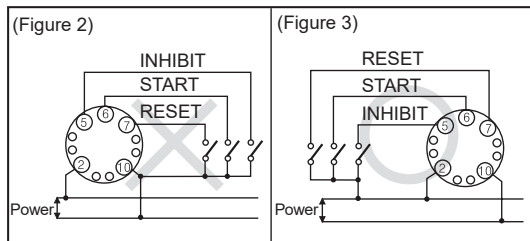

- When controlling several timers by one input contact or transistor, do not wire it as (Figure 4). This wiring causes short current due to not accorded phase of power. Wire it as (Figure 5) to accord to phase of power.

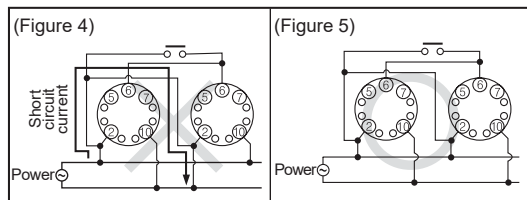

- In order to apply input signals (INHIBIT, START, RESET), short-circuit the terminal no. ②-⑤, ②-⑥ or ②-⑦. It may cause internal circuit damage by wrong connections.
- Do not wire INHIBIT, START, RESET signal input line with power line, high voltage line in parallel.
- Use shield cable when input (INHIBIT, START, RESET) cable is longer. Cable length should be as short as possible.

◎ Common

- Be sure that when using a timer at high temperature for a long time, it may cause deterioration for inner parts (electrolytic condenser, etc.).
- In case of 12VDC, 24VDC, 24VAC model, isolated and limited voltage/current or Class 2 source should be provided for power supply.
- When supply the power to the Timer, connection shown in (Figure 6) might cause malfunction due to leakage current through R and C. Please connect R and C as shown in (Figure 7) to prevent malfunction.

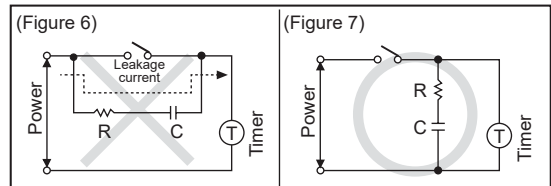

- Do not use this unit at below places.
 - Place where there are severe vibration or impact.
 - Place where strong alkalis or acids are used.
 - Place where there are direct ray of the sun.
 - Place where strong magnetic field or electric noise are generated.

- Installation environment
 - Indoors
 - Altitude Max. 2,000m
 - Pollution Degree 2
 - Installation Category II